

Easy Pallet Transport Truck

With a rated capacity of 7717 lbs TM hand pallet truck is rugged, reliable for all working condition.

Optimum working condition for the user-ergonomically plastic coated handle and volkulon wheel ensure a minimum starting power and correct handling of even very heavy pallets - both when pulling and pushing the truck.

The design prevent industrial injuries and strain on the user - focus is put on safety and ergonomic working condition of the user. The ergonomically correct shape of the handle ensures a relax hold for the user.

High quality is ensured through an extended test programme and in cooperation with expert in health and safety.





Ergonomic handle ensures the user a relaxed hold. Can be marked with name/department.



The hoop skates on the forks ensure an easy fork insertion and withdrawal in/out of pallets.



The company name or logo can be cut out in the triangle of the Panther.

Product (measured in mm)	1672	1682	2572	2582	3072	3082
Capacity in kg	1600		2500		3000	
Lifting height	h_3		$h_{13} + 120$			
Fork length	600, 810, 970, 1140		600, 810, 915, 970, 1066, 1140, 1220, 1520, 1800, 2000, 2400*		600, 810, 915, 970, 1140, 1220, 1520	
Overall height	h_1		$h_{13} + 412$			
Fork span	b_5 450		520, 680		520, 680	
Length without forks	l_2		335			
Overall length	l_1		$l + 335$			
Fork width	e 125		160			
Wheelbase	y		$l + 25$			
Overall height	h_{14}		1170			
Lowered height - adjustable	h_{13} 75 to 83	85 to 93	75 to 83	85 to 93	75 to 83	85 to 93
Load centre	c		$l / 2$			
Ground clearance	m_2		$h_{13} - 47$			
Turning angle of the wheels	220°					
Fork wheels - single	Ø75 x 68	Ø85 x 68	Ø75 x 90	Ø85 x 90		
Fork wheels - tandem			Ø75 x 68	Ø85 x 68	Ø75 x 68	Ø85 x 68
Steering wheel	Ø200 x 50					
Weight	59 kg (450 x 1140)		62 kg (520 x 1140)		68 kg (520 x 1140)	

* Reduced capacity 1500 kg

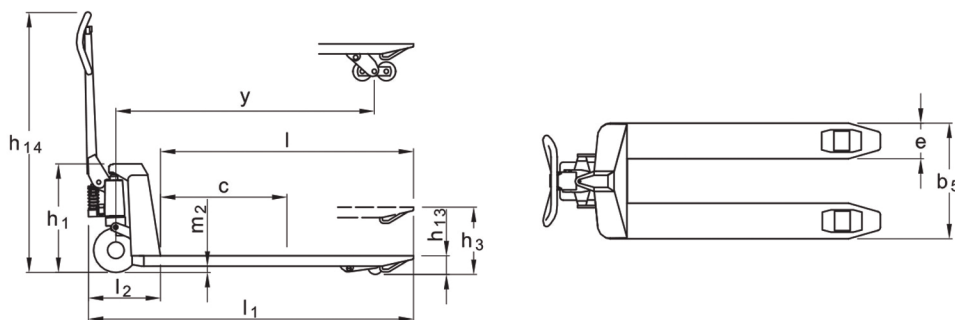

Your Authorized Dealer